



ak SINK
Bahraini Brand



+973 17879130

+973 17879135

ak@Alkarrargroup.com

anwar alkarrar

alkarrargroup

alkarrargroup



AAKSI001



DESCRIPTION

Electroplated finish , bottom with silencing pad and dark spray coating

MATERIAL

STAINLESS STEEL 304

THICKNESS

0.7

DIMENSION

500*420*190

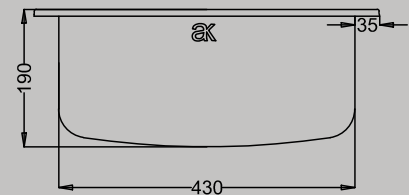
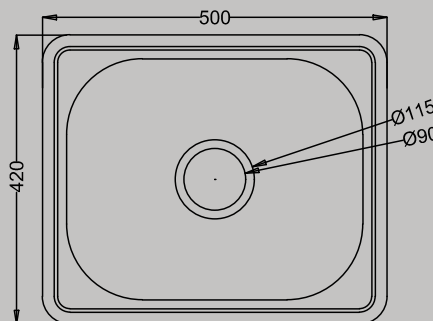



AAKSI002



DESCRIPTION

Electroplated finish , bottom with silencing pad and dark spray coating

MATERIAL

STAINLESS STEEL 304

THICKNESS

0.7

DIMENSION

413*375*210

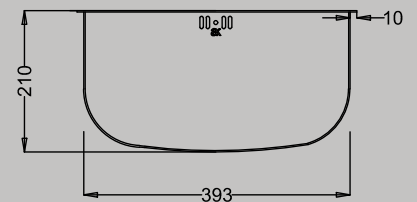
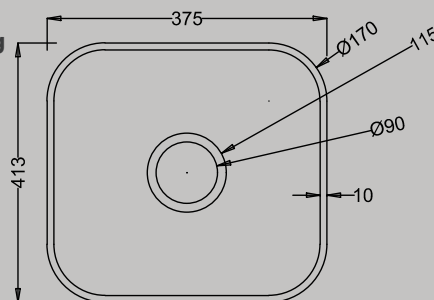



● **AAKSI003**



DESCRIPTION

Electroplated finish , bottom with silencing pad and dark spray coating

MATERIAL

STAINLESS STEEL 304

THICKNESS

0.7

DIMENSION

800*500*190

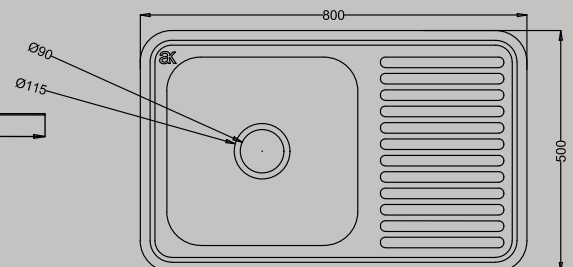
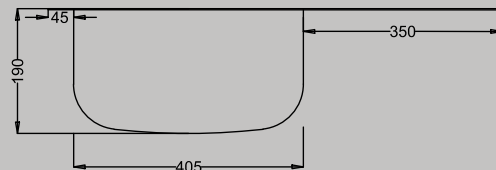

The logo consists of a white lowercase 'a' and 'k' inside a blue square, which is itself inside a larger orange square.

AAKSI004



DESCRIPTION

Electroplated finish , bottom with silencing pad and dark spray coating

MATERIAL

STANLESS STEEL 304

THICKNESS

0.9

DIMENSION

800*500*230

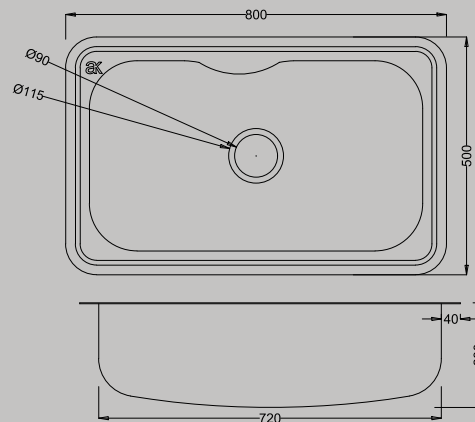



AAKSI005



DESCRIPTION

Electroplated finish , bottom with silencing pad and dark spray coating

MATERIAL

STAINLESS STEEL 304

THICKNESS

0.8

DIMENSION

830*480*220

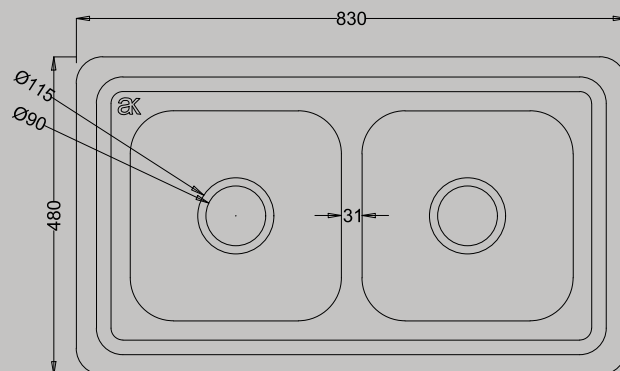
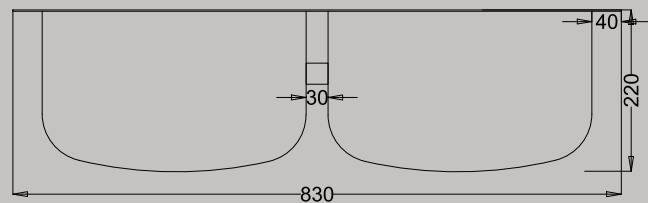



AAKSI006



DESCRIPTION

Electroplated finish , bottom with silencing pad and dark spray coating

MATERIAL

STAINLESS STEEL 304

THICKNESS

0.8

DIMENSION

1200*495*220

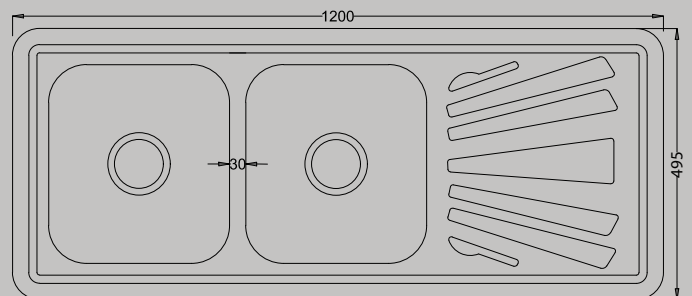
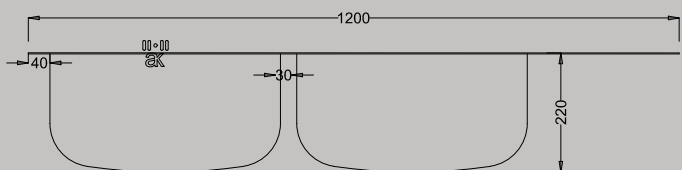



AAKSI007



DESCRIPTION

Electroplated finish , bottom with silencing pad and dark spray coating

MATERIAL

STANLESS STEEL 304

THICKNESS

1

DIMENSION

798*456*227

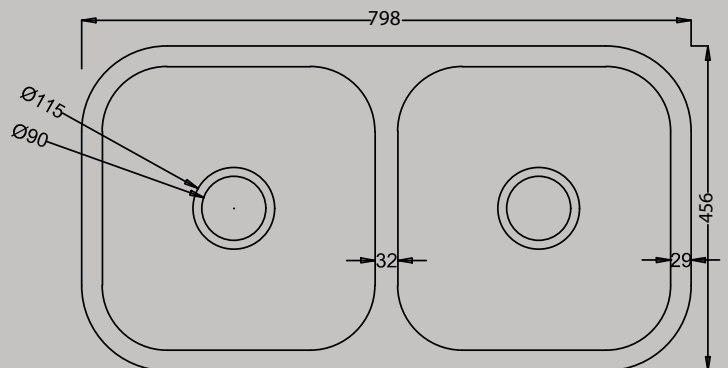
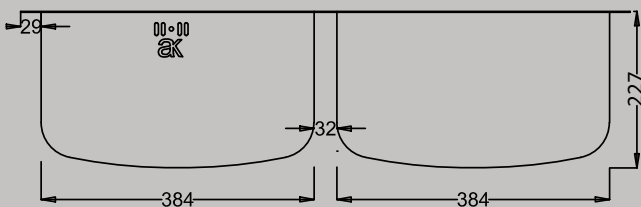



AAKSI008



DESCRIPTION

matt /brush finish bottom
w/silencing pad and dark spray coating

MATERIAL

STAINLESS STEEL 304

THICKNESS

1

DIMENSION

786*483*220

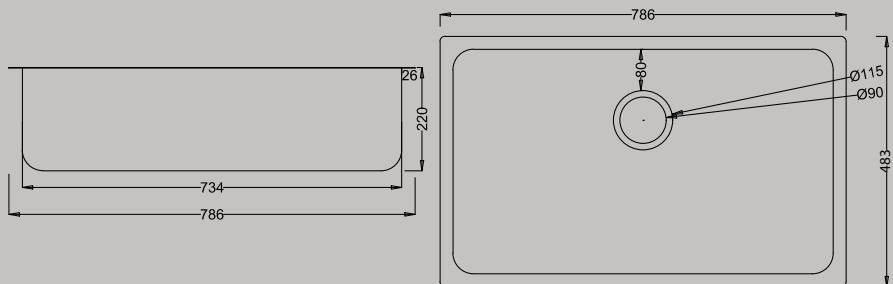



AAKSI009



DESCRIPTION

matt /brush finish bottom
w/silencing pad and dark spray coating

MATERIAL

STAINLESS STEEL 304

THICKNESS

1

DIMENSION

440*440*218

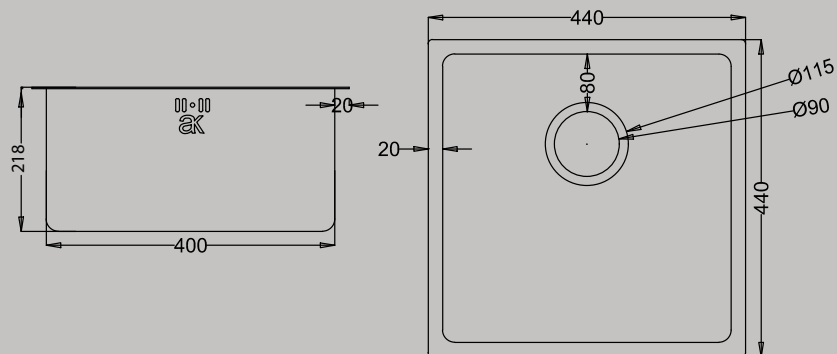



AAKSI010



DESCRIPTION

Brush/satin finish, bottom with silencing pad and spray coating

MATERIAL

STAINLESS STEEL 304

THICKNESS

1

DIMENSION

780*482*219

